

# TUNEL 6 SEGMENTÓW INSTRUKCJA MONTAŻU

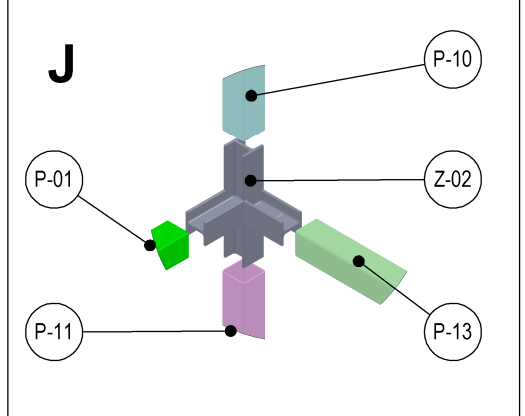

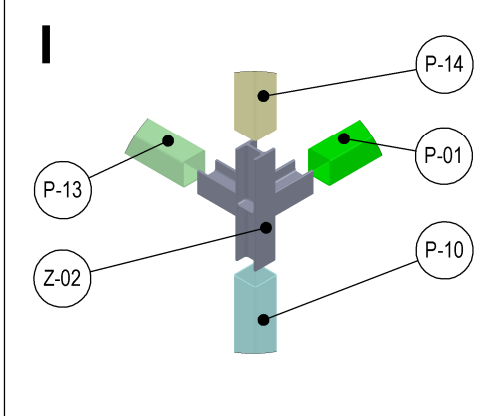

P-01  
Długość: L=640 mm  
Widok: A-E,G,I-N  
Ilość: 40

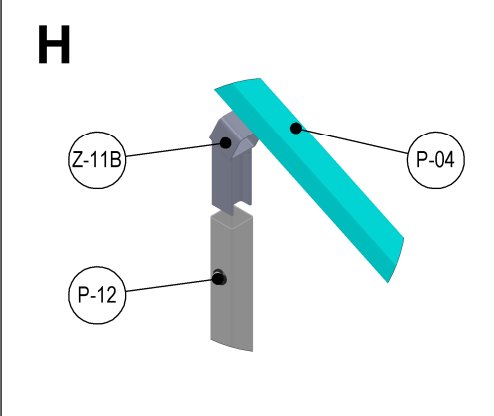
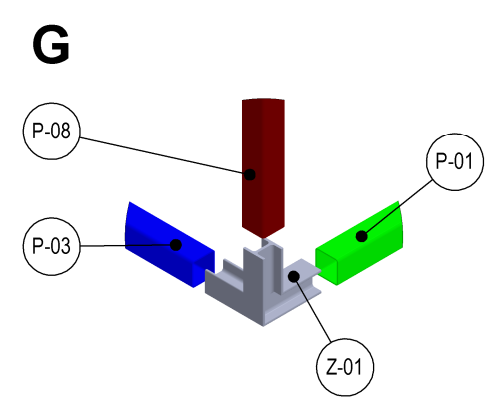
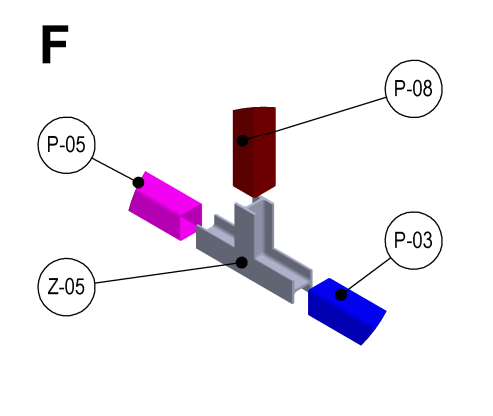
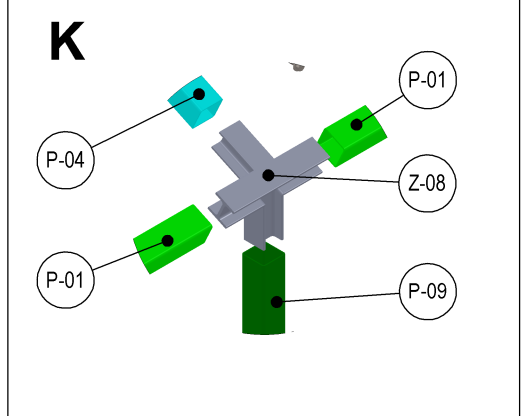
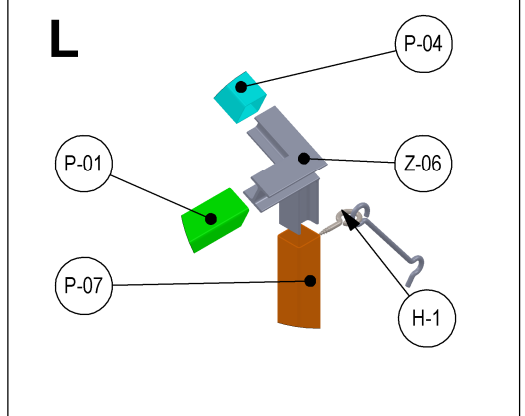
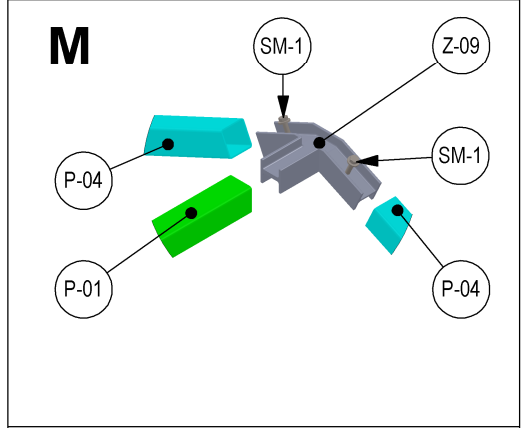
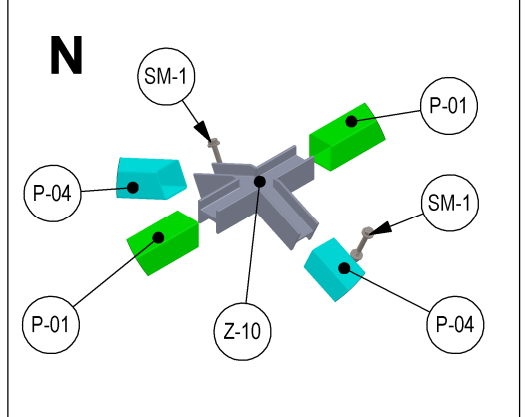
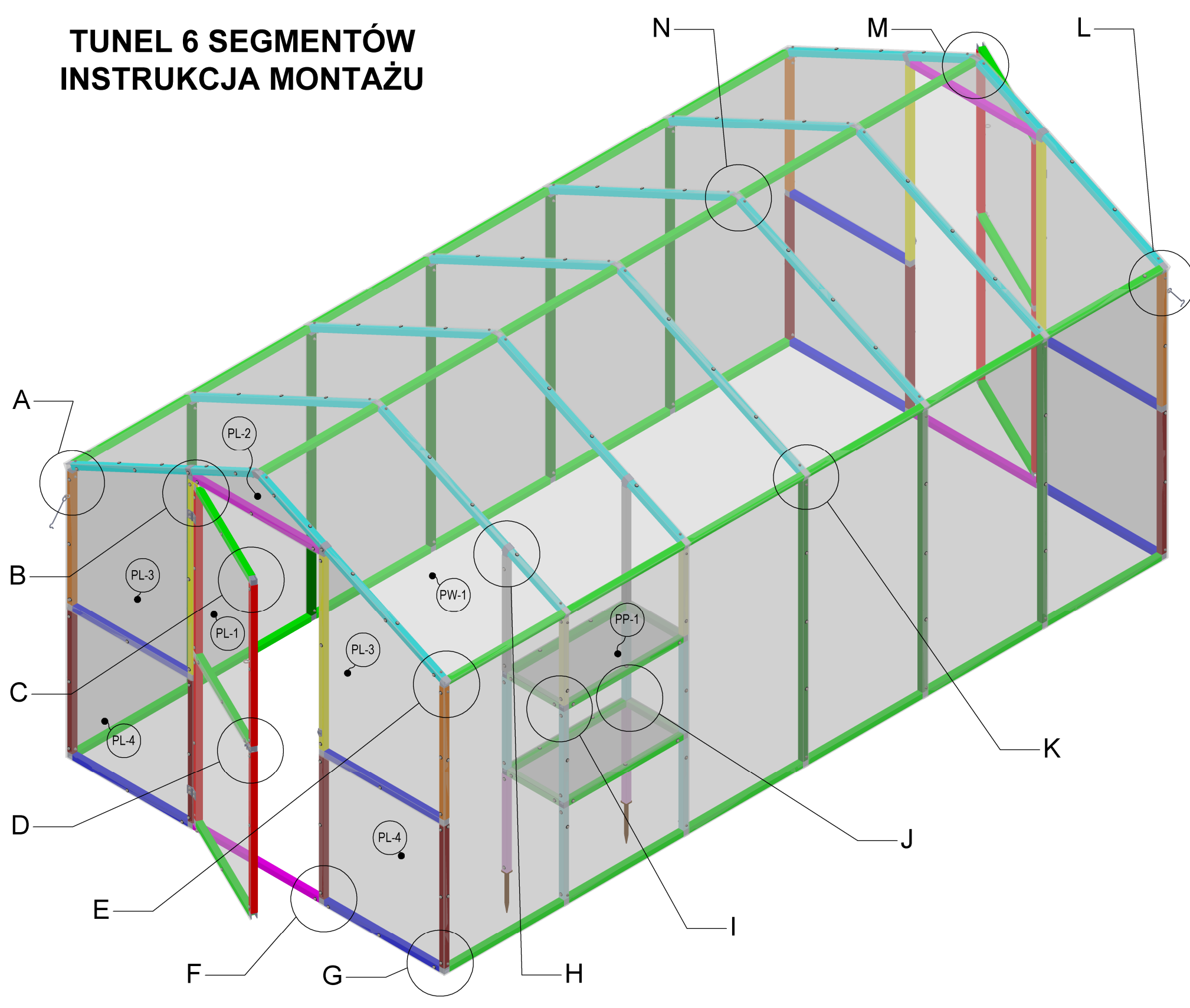
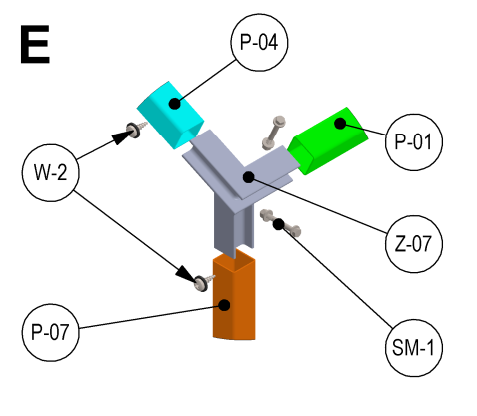
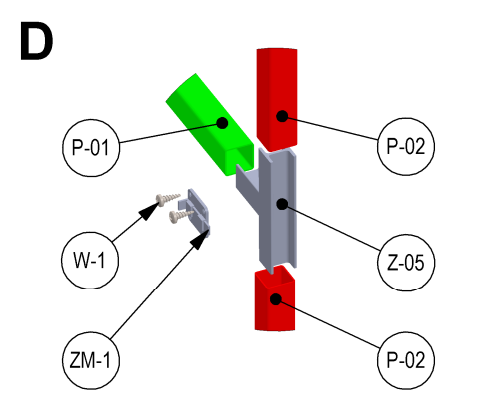
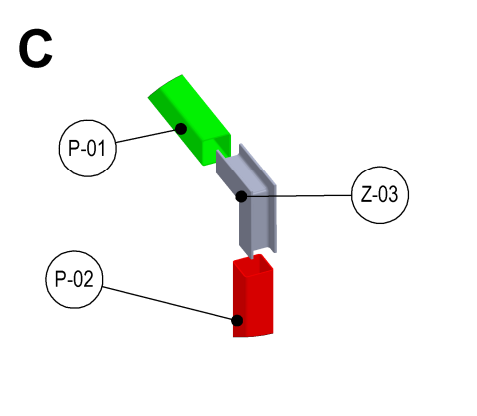
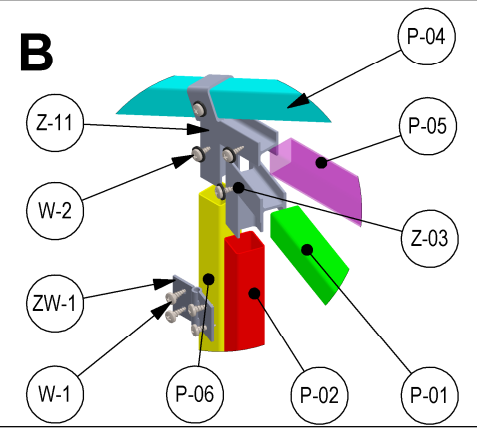
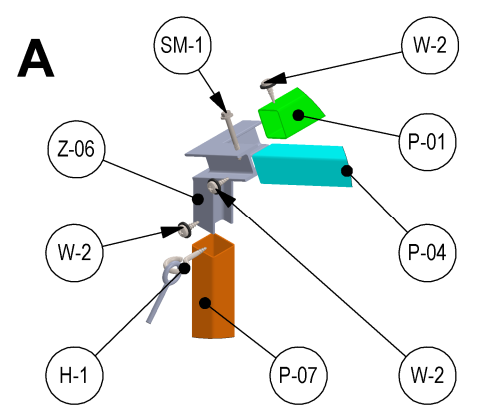
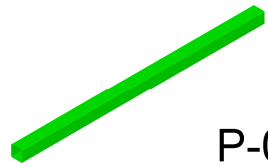
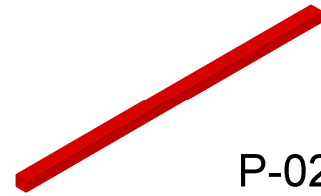

P-02  
Długość: L=780 mm  
Widok: B-D  
Ilość: 8

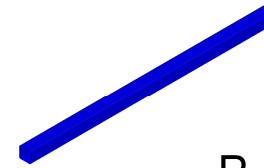

P-03  
Długość: L=645 mm  
Widok: F,G  
Ilość: 8

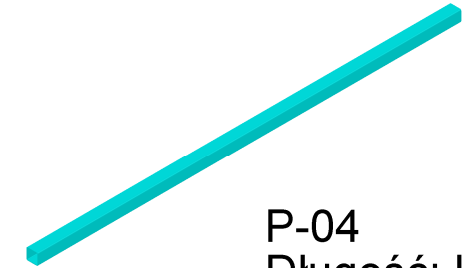

P-04  
Długość: L=1120 mm  
Widok: A,B,E,H,K-N  
Ilość: 14

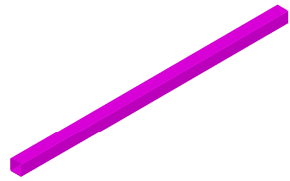

P-05  
Długość: L=705 mm  
Widok: B,F  
Ilość: 4

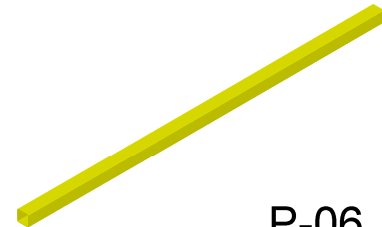

P-06  
Długość: L=940 mm  
Widok: B  
Ilość: 4



P-07  
Długość: L=640 mm  
Widok: A,E,L  
Ilość: 4

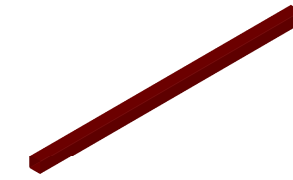

P-08  
Długość: L=690 mm  
Widok: F,G  
Ilość: 8

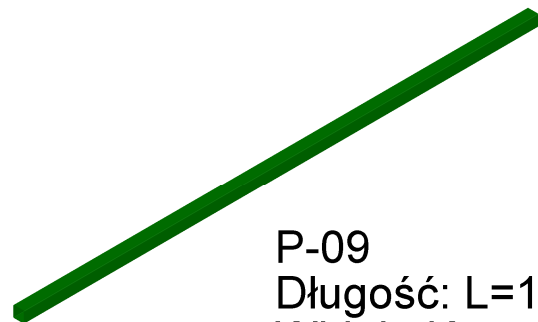

P-09  
Długość: L=1360 mm  
Widok: K  
Ilość: 8

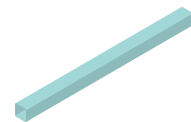

P-10  
Długość: L=440 mm  
Widok: I,J  
Ilość: 6

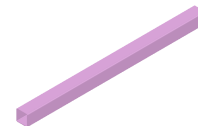

P-11  
Długość: L=470 mm  
Widok: J  
Ilość: 2

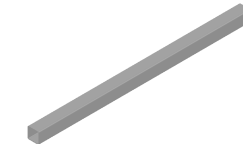

P-12  
Długość: L=560 mm  
Widok: H  
Ilość: 2



P-13  
Długość: L=290 mm  
Widok: I,J  
Ilość: 4



P-14  
Długość: L=420 mm  
Widok: I  
Ilość: 2



H-1  
Widok: A,L  
Ilość: 2

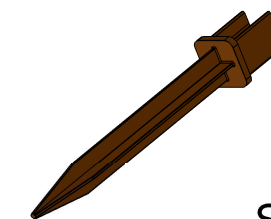

SZ-2  
Widok: Ogólny  
Ilość: 2

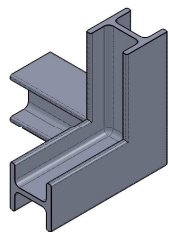

Z-01  
Widok: G  
Ilość: 4

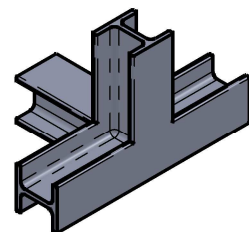

Z-02  
Widok: I,J  
Ilość: 8

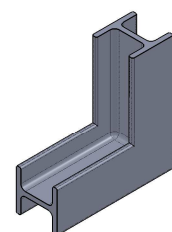

Z-03  
Widok: B,C  
Ilość: 8

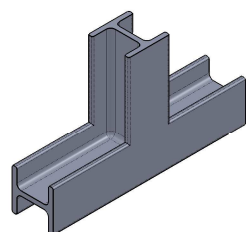

Z-05  
Widok: D,F  
Ilość: 26



PL-1  
Drzwi  
Widok ogólny  
Ilość: 4

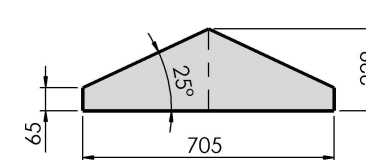

PL-2  
Front  
Widok ogólny  
Ilość: 2

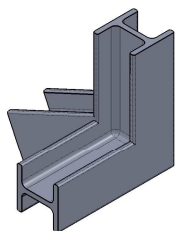

Z-06  
Widok: A,L  
Ilość: 2

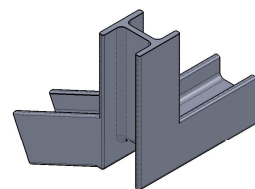

Z-07  
Widok: E  
Ilość: 2

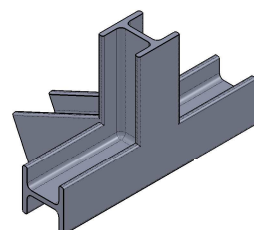

Z-08  
Widok: K  
Ilość: 10

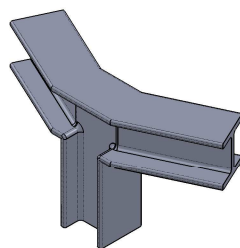

Z-09  
Widok: M  
Ilość: 2

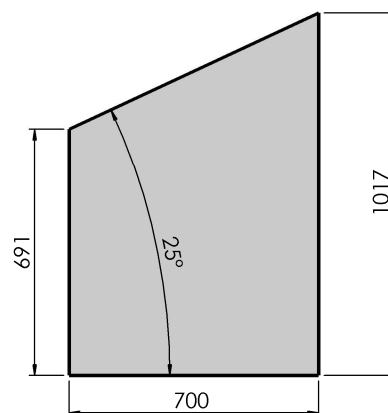

PL-3  
Front góra  
Widok ogólny  
Ilość: 4

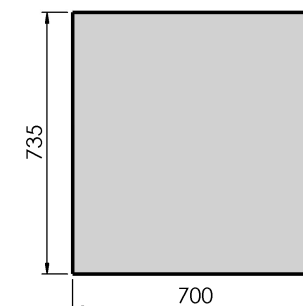

PL-4  
Front dół  
Widok ogólny  
Ilość: 4

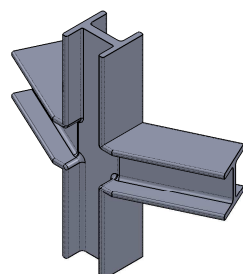

Z-10  
Widok: N  
Ilość: 5

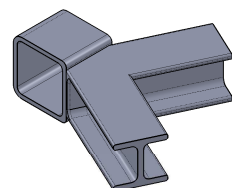

Z-11  
Widok: B  
Ilość: 4

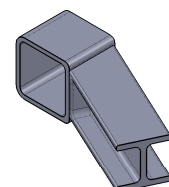

Z-11B  
Widok: H  
Ilość: 2

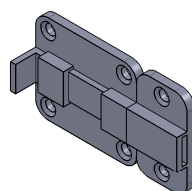

ZM-1  
Widok: D  
Ilość: 2

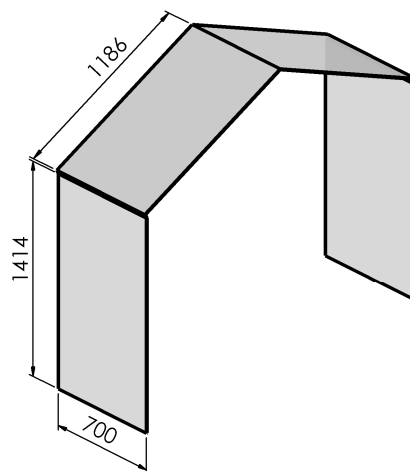

PW-1  
Dach, Ściana  
Widok ogólny  
Ilość: 6

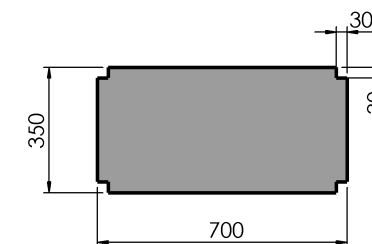

PP-1  
Półka  
Widok ogólny  
Ilość: 2

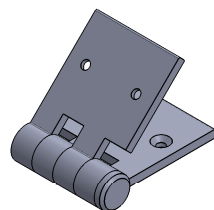

ZW-1  
Widok: B  
Ilość: 6

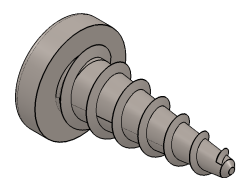

W-1  $\phi$  5x20  
Widok: B,D  
Ilość: 50

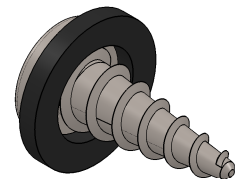

W-2  $\phi$  5x25  
Widok: A,B  
Ilość: 200

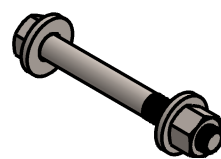

SM-1 M5x50  
Widok: A,E,M,N  
Ilość: 50

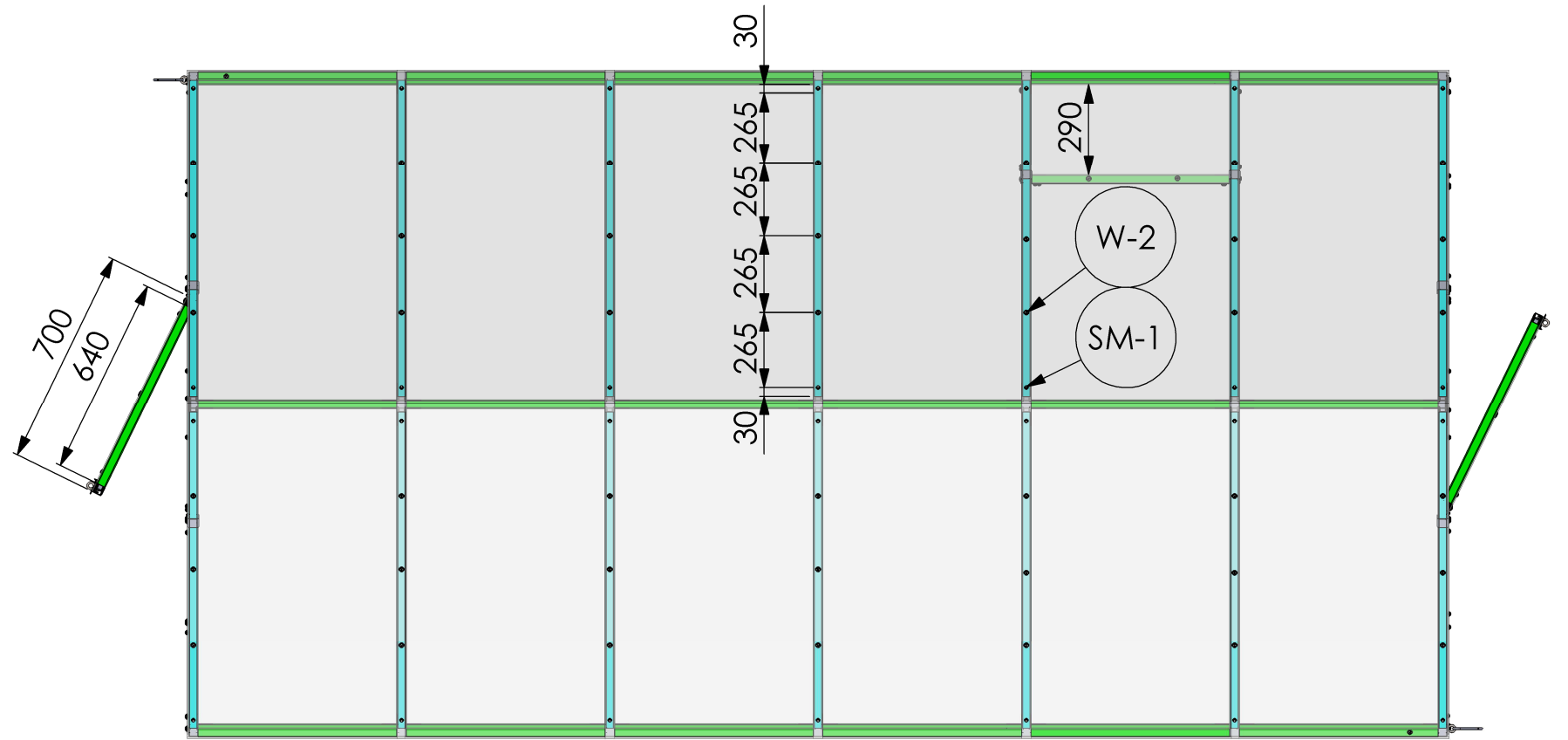
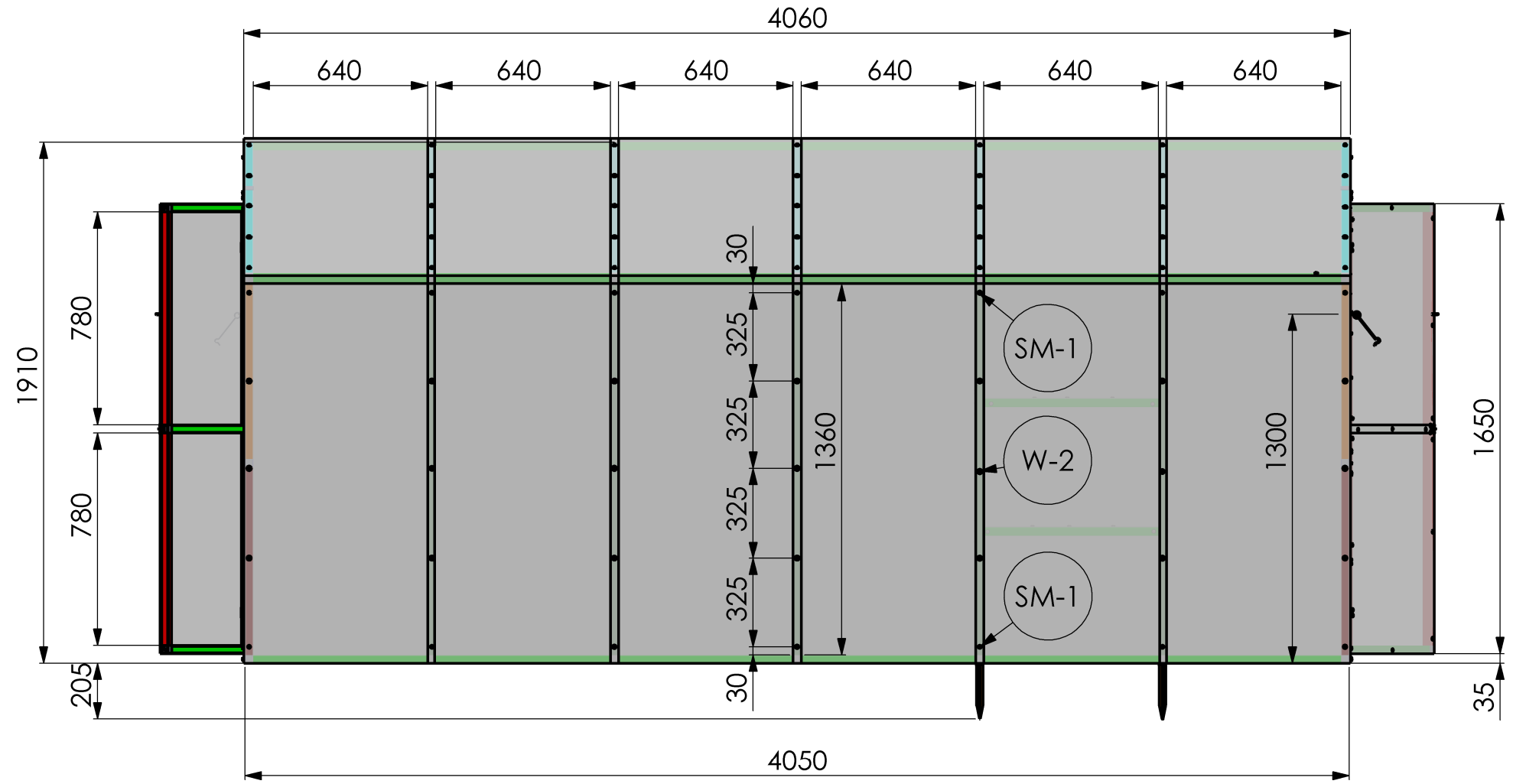
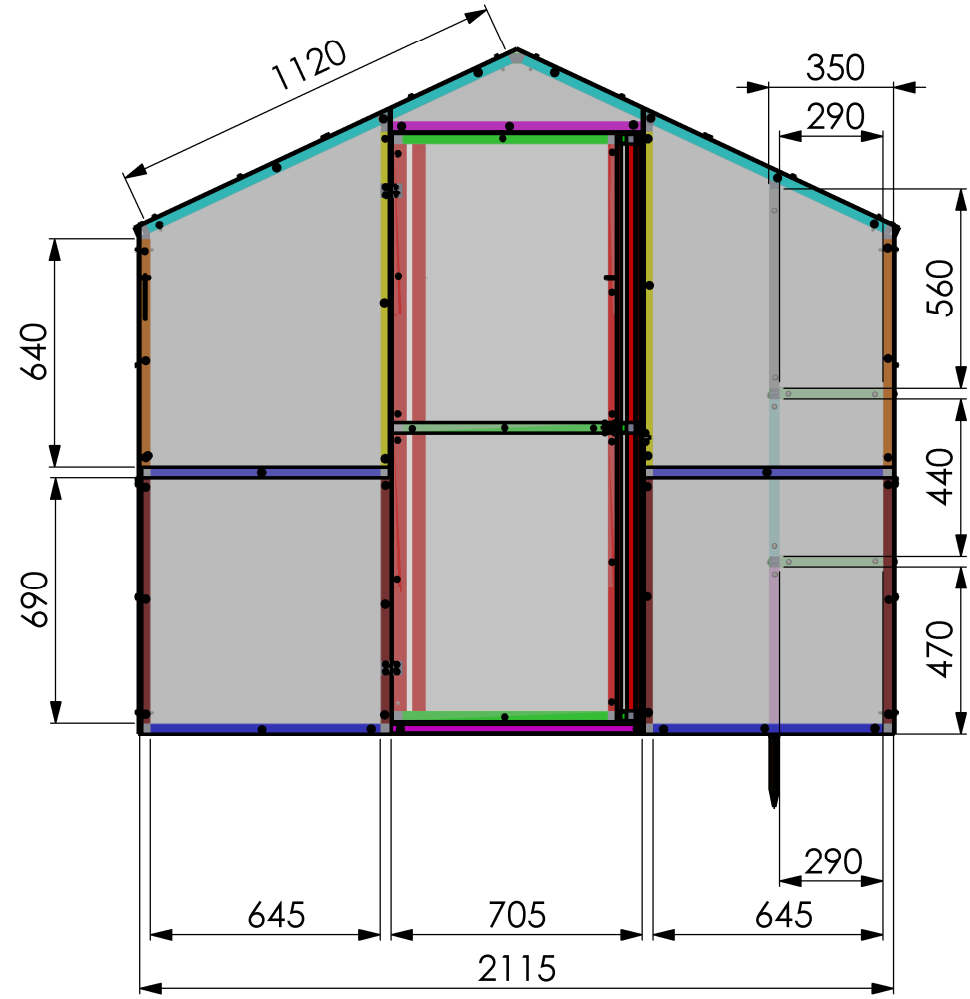

# ROZMIESZCZENIE ŚRUB

